

SPECIFICATIONS:  
 MAGNET WIRE: Ø 0.13/1.00 mm (18/36 AWG)  
 LEAD WIRE: 0.3/0.8 sqmm (18/22 AWG )  
 Ø 2.9 mm max insulation  
 POCKET RECOMMENDATION: 551014

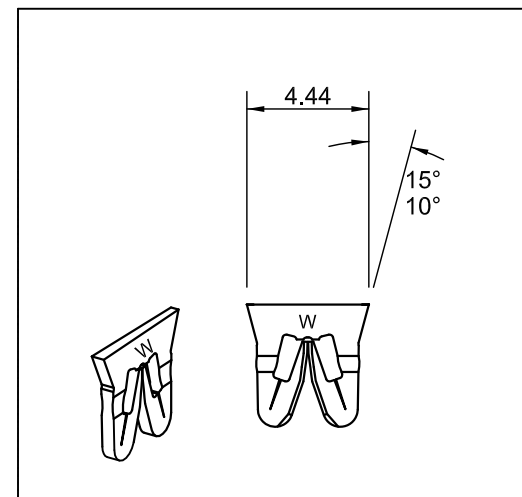

TERMINAL FEED LH

TERMINAL FEED RH

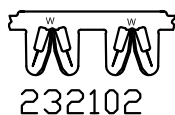
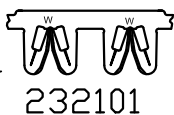

Drawn by LB	Drawing	Material Brass	Finish None	Scale 1/1	Date 20/01/12
<b>Wirecon S.r.l.</b>		Tolerances ± 0.13			
		Title WIRE TERMINAL			
		File name 232101 --- 232102			